



Pressure Transmitter HDA 4800 for Iron and Steelworks

Relative pressure Accuracy 0.125 %



Includes test certificate

Description:

This high-precision pressure transmitter was specially developed and adapted for the sophisticated measurement demands of steelworks technology.

The instrument has a very robust sensor cell with a thin-film strain gauge on a stainless steel membrane.

Its outstanding specifications in respect of temperature effect (temperature drift for zero point and span are in each case max. $\leq \pm 0.01$ % FS / °C) and accuracy ($\leq \pm 0.125$ % FS typ.) make it ideally suited for use in the environmental conditions found in steelworks.

The excellent EMC characteristics guarantee signal stability during the harshest high-frequency, electromagnetic interference.

Additional protection against humidity and vibrations is achieved by encapsulation. A heat shrink sleeving is used to protect the sensor from bending.

Technical data:

Input data											
Measuring ranges ¹⁾	bar	16	60	100	150	250	300	350	400	500	600 1000
Overload pressures	bar	32	120	200	500	800	900	900	900	1000	1000 1600
Burst pressure	bar	200	300	500	1000	2000	2000	2000	2000	2000	2000 3000
Mechanical connection ¹⁾	G 1/4A ISO 1179-2 with 0.5 mm orifice G 1/2A ISO 1179-2 with 0.5 mm orifice										
Tightening torque, recommended	20 Nm (G1/4); 45 Nm (G1/2)										
Parts in contact with fluid	Mech. connection: Stainless steel Seal: FKM for G1/4, NBR for G1/2										
Output data											
Output signal, permitted load resistance	4 .. 20 mA, 2-conductor $R_{Lmax} = (U_B - 10 V) / 20 \text{ mA}$ [kΩ] 0 .. 20 mA, 3-conductor source $R_{Lmax} = (U_B - 4 V) / 20 \text{ mA}$ [kΩ]										
Accuracy acc. to DIN 16086, terminal based	$\leq \pm 0.125$ % FS typ. $\leq \pm 0.25$ % FS max.										
Accuracy, B.F.S.L.	$\leq \pm 0.06$ % FS typ. $\leq \pm 0.125$ % FS max.										
Temperature compensation	$\leq \pm 0.005$ % FS / °C typ.										
Zero point	$\leq \pm 0.01$ % FS / °C max.										
Temperature compensation	$\leq \pm 0.005$ % FS / °C typ.										
Span	$\leq \pm 0.01$ % FS / °C max.										
Non-linearity acc. to DIN 16086, terminal based	$\leq \pm 0.15$ % FS max. (below 100 bar ± 0.2 % FS max.)										
Hysteresis	$\leq \pm 0.1$ % FS max.										
Repeatability	$\leq \pm 0.05$ % FS										
Rise time	≤ 1.0 ms										
Long-term drift	$\leq \pm 0.1$ % FS typ. / year										
Environmental conditions											
Compensated temperature range	-25 .. +85 °C										
Operating temperature range ²⁾	-25 .. +85 °C / -40 .. +85 °C										
Storage temperature range	-40 .. +100 °C										
Fluid temperature range ²⁾	-25 .. +100 °C / -40 .. +100 °C										
CE mark	EN 61000-6-1 / 2 / 3 / 4										
UL US mark ³⁾	Certificate-No.: E318391										
Vibration resistance acc. to DIN EN 60068-2-6 at 10 .. 500 Hz	≤ 25 g										
Protection class acc. to DIN EN 60529	IP 67 (M12x1 when an IP 67 mating connector is used) IP 68 (jacketed cable)										
Other data											
Supply voltage when applied acc. to UL specifications	10 .. 30 V DC 2-conductor / 3-conductor - limited energy - acc. to 9.3 UL 61010; Class 2; UL 1310/1585; LPS UL 60950										
Residual ripple of supply voltage	≤ 5 %										
Current consumption	≤ 25 mA										
Additional protection against water, humidity and vibration	Encapsulation of the device, cable outlet with strain relief, heat shrink sleeving										
Life expectancy	>10 million cycles (0 .. 100 % FS)										
Weight	~180 g plus 90 g/m cable										

Note: Reverse polarity protection of the supply voltage, excess voltage, override and short circuit protection are provided.

FS (Full Scale) = relative to complete measuring range

B.F.S.L. = Best Fit Straight Line

¹⁾ 1000 bar only with mech. connection G1/2 A ISO1179-2 and vice versa

²⁾ -25 °C with FKM seal, -40 °C on request

³⁾ Environmental conditions acc. to 1.4.2 UL 61010-1; C22.2 No. 61010-1

Dimensions:

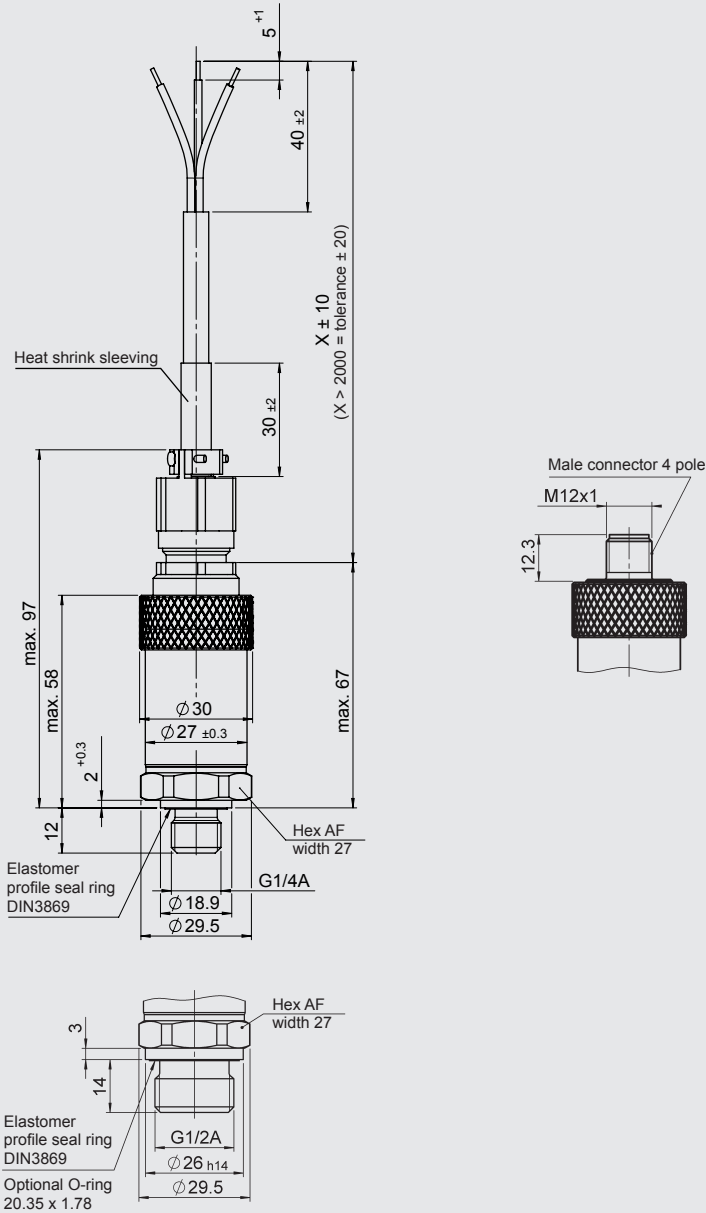

Cable assignment:

Lead	HDA 48X0-A	HDA 48X0-E
black	n.c.	+U _B
Brown	Signal +	Signal
Blue	Signal -	0 V

Cable type:

Ölfion cable 3 x 0.75 mm² shielded.
Outer sheath FEP black
Outer diameter 5.9 ± 0.15 mm

Pin connections:

M12x1

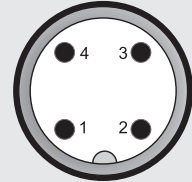

Pin	HDA 48X6-A	HDA 48X6-E
1	Signal +	+U _B
2	n.c.	n.c.
3	Signal -	0 V
4	n.c.	Signal

Model code:

HDA 4 8 X X - X - XXXX - 424 (XXM)

Mechanical connection

- 2 = G 1/2 A ISO 1179-2 (male)
- 4 = G 1/4 A DIN 3852 (male)

Electrical connection

- 0 = jacketed cable
- 6 = male M12x1, 4 pole
(mating connector not supplied)

Output signal

- A = 4 .. 20 mA, 2-conductor
- E = 0 .. 20 mA, 3-conductor

Measuring ranges in bar

0016; 0060; 0100; 0150; 0250; 0300; 0350; 0400; 0500; 0600;
1000 (only with mech. connection G1/2")

Modification number

424 = iron and steel works

Cable length in metres

06; 10; 15; 20; 25; 30

Note:

On instruments with a different modification number, please read the label or the technical amendment details supplied with the instrument.

Note:

The information in this brochure relates to the operating conditions and applications described.

For applications or operating conditions not described, please contact the relevant technical department.

Subject to technical modifications.

HYDAC ELECTRONIC GMBH

Hauptstraße 27, 66128 Saarbrücken
Germany
Telephone +49 (0)6897 509-01
Fax +49 (0)6897 509-1726
E-mail: electronic@hydac.com